



THE STANDARD IN PV MOUNTING STRUCTURES™

*You're taking an environmental stand . . .
Make it an architectural statement*



SUNFRAME®
PV MODULE MOUNTING SYSTEM

U.S. and other patents pending

www.unirac.com



SUNFRAME[®]
PV MODULE MOUNTING SYSTEM

Clean energy never looked this good

Low lines

SunFrame stands off the roof just enough for cooling air flow to optimize module performance.

Clean lines

All modules sit in low, gap-free rows. No rails protrude from the sides of the array.

Finish options

SunFrame components are anodized to match the color of the module frames.

Front yard friendly

A completed SunFrame installation blends handsomely into the roof, becoming as natural a part of a home or business as a skylight.

Façade SunFrame

Mount SunFrame vertically for a triple benefit: Cladding shades and cools your building, produces PV power, and looks great.



Manage modules hands-free

Slide unsecured modules along the rails to provide access and work space. They'll stay put during wiring.



Enjoy installation-friendly features

Testing ensures code compliance

Destructive testing and analysis by an independent laboratory verify that all SunFrame components meet our rigorous design criteria.



Minimize drilling

Cap strip screw threads grip a threaded slot atop SunFrame rail extrusion, securing modules.

Place flashings easily

Precisely place a flashing over the secured base of a two-piece aluminum standoff prior to the installation of the standoff itself.

Manage the small stuff

Secure wiring with cable ties. Smooth out roof irregularities with shims.

Streamline inspections

UniRac documentation provides the technical information to demonstrate SunFrame's structural integrity and to ease permitting. Follow our step-by-step procedures to satisfy your building inspector.

Take advantage of flexible options

L-Foot adjusting sliders ensure that rails align properly and snug firmly against modules with no aesthetic compromise. Utility slots provide an easy means to secure system components.

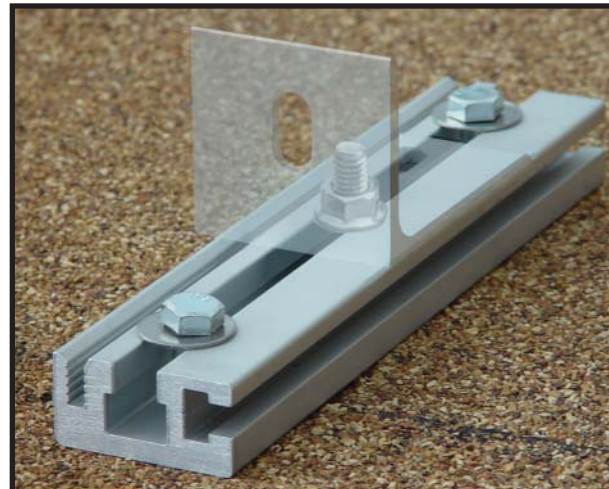

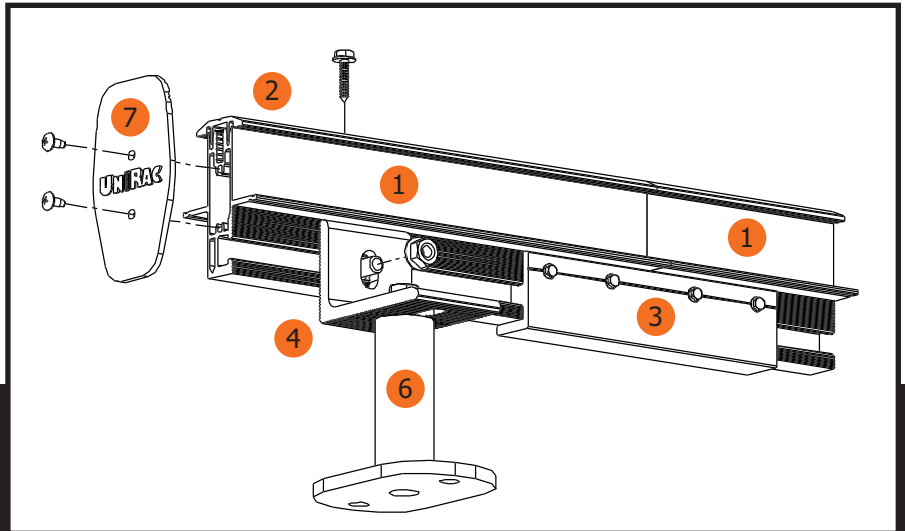

System components

- 1. Rails.** Modules are supported between SunFrame rails, not on top of them. The array is lower to the roof, enhancing its integrated appearance. A threaded slot atop the rail makes for quick and secure module mounting. Should it ever become necessary, replace modules easily.
- 2. Cap strips.** SunFrame cap strips hold modules securely. Because the strips are pre-punched, you never have to drill.
- 3. Splices.** Hidden splices are used to create long rows of modules. If required, install them to allow thermal expansion. Consult SunFrame installation instructions for details.
- 4. L-feet.** Serrated L-feet attach directly to asphalt shingle roofs or rest on adjusting sliders or standoffs.
- 5. L-foot adjusting sliders.** L-feet can be easily adjusted along fixed sliders to ensure that rails fit snugly against the modules.
- 6. Standoffs and flashings.** Two-piece standoffs speed installation on tile roofs. We offer six flashing choices for our aluminum or steel standoffs.
- 7. End caps.** UV resistant black end caps neatly finish off the installation.

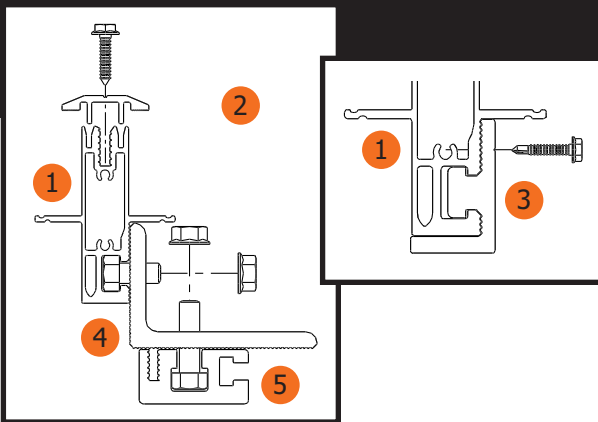

THE STANDARD IN PV MOUNTING STRUCTURES™

UniRac, Inc.

3201 University Blvd. SE, Suite 110, Albuquerque NM 87106-5635 USA

505.242.6411

505.242.6412 Fax

Pub 051001 • October 2005

© 2005 UniRac, Inc. All rights reserved.

Module compatibility

Use SunFrame with PV modules from these major manufacturers: BP Solar, Evergreen, First Solar, GE Energy, Isofoton, Kaneka, Kyocera, Mitsubishi, Photowatt, RWE Schott, Sanyo, Sharp, Shell, SunPower, SunWize, and UniSolar.

Component specs

Rails, cap strips, two-piece standoffs, splices, L-foot, and L-foot sliders: 6105-T5 aluminum extrusion.

End caps: UV resistant plastic.

One-piece standoffs: Condition 4 (very severe) zinc-plated welded steel.

Fasteners: 304 stainless steel.

Warranty

SunFrame is covered by a 10-year limited product warranty and 5-year limited finish warranty. For specific details, download the SunFrame Code Compliant Planning and Assembly manual from www.unirac.com.

www.unirac.com

See our SunFrame page for additional information: pricing, an installation manual appropriate to your building code, additional on-site images, and a great new tool for determining and costing minimum component requirements for your unique job.